

FLAT PANEL MONITORS

29LM151(61MP) SERIES

15.0" LCD MONITOR HEADS

DISPLAY

Type:	AM Colour TFT
No. Colours:	256k
Max. Resolution:	1024 x 768 pixels
Active Display Area:	304 x 228mm
Backlight Life:	50,000 hours typical
Brightness:	230cd/m ² typical
Contrast Ratio:	400:1 typical.
Viewing Angles:	160° H, 160° V

SIGNAL INPUTS

Input A:

RGB:	Analog RGB 0.7-1.0Vp-p
Input Connector:	15-pin HD Female
Sync. Type/Level:	Separate H&V (+/-ve) TTL

Input B:

Video:	PAL or NTSC standard
Input Connector:	RCA
Sync. Type/Level:	Composite (CVBS) 1Vp-p

Multiscan Support:	1024 x 768 XGA 800 x 600 SVGA 640 x 480 VGA
--------------------	---

Horizontal Scan:	15 (PAL) - 60kHz
Vertical Scan:	60Hz

User Controls:	None
Set Up Controls:	(At rear) Autoseup + full OSD menu via pushbuttons

POWER

DC Model:	12Vdc or 15-30Vdc
Connector:	3 pin DIN
AC Model:	110/230V 50/60Hz via separate 12Vdc power pack.
Power Consumption:	30W Max.

PHYSICAL/ENVIRONMENTAL

Dimensions (approx):	388 x 296 x 60mm
Weight (approx):	3Kg.
Housing:	Aluminium (Storm Grey)
Operating Temp:	0 to 50°C
Storage Temp:	-20 to 60°C

PART NUMBERS

12Vdc model:	29LM151E61MP/3
15-30Vdc model:	29LM151D61MP/3
12Vdc model with Resistive Touch	29LM151ER61MP/3
AC Power Pack:	20BK0234H

No Frills Video +XGA models



- **XGA (1024 x 768 pixels) resolution**
- **Lightweight Metal Construction**
- **High Brightness & Wide Viewing Angles**
- **Automatic Image Size Adjustment**
- **Vibration-proof Locking Connector for power**
- **Toughened Non-Glare Safety Glass protection**
- **Optional Touchscreen integration**
- **Also available in Desktop, Open Chassis, Rack & Panelmount formats**

The **29LM151(61MP)** Series of LCD monitor heads has been designed for industrial applications that require a compact VGA/XGA compatible monitor with good viewability. It is constructed from painted Aluminium, making it lightweight with good rigidity. VESA fixings at the rear make for easy wall mounting or use with Ergo arms. Side and/or Top fixing brackets are also available.

The **29LM151(61MP)** Series incorporates PAL/NTSC capability in addition to RGB, opening applications in security, surveillance and machine vision systems. Power & Signal connectors exit vertically downwards allowing the installer to take full advantage of the monitor's 60 mm depth.

The **61MP series** has been designed as a cost-effective alternative to our **51UN series** 15.0" display that is designed specifically for Legacy Signals up to XGA resolution.

Due to a policy of continuous product development KME reserves the right to change specifications and descriptions without prior notification. All trade marks acknowledged. 29lm151(61mp)1 09/2004

MONITORS & DISPLAY MODULES



INTELLIGENT DISPLAY SOLUTIONS



29LM151(61MP) SERIES

15.0" TFT MONITOR HEAD

FRONT VIEW

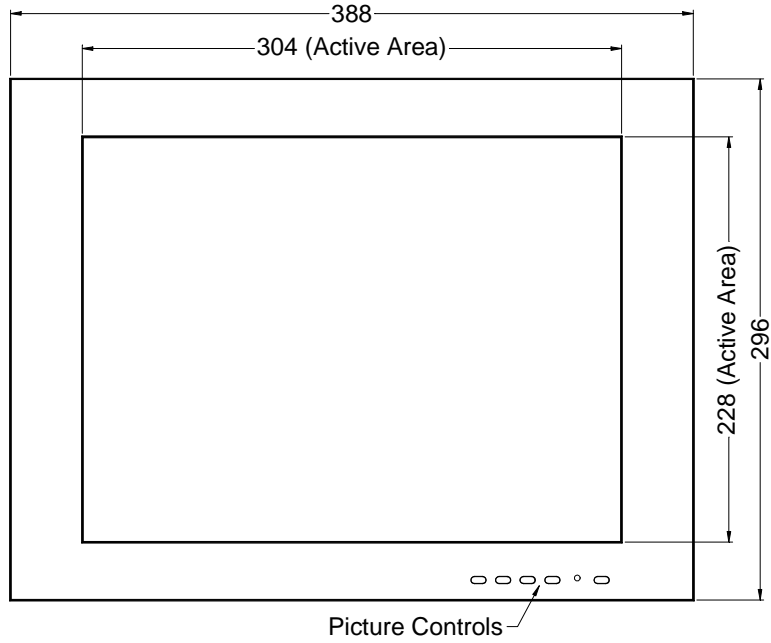

SIDE VIEW

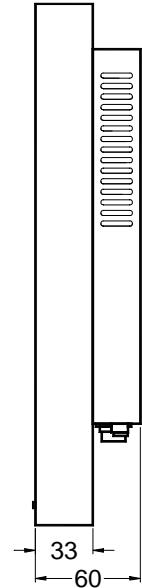

REAR VIEW

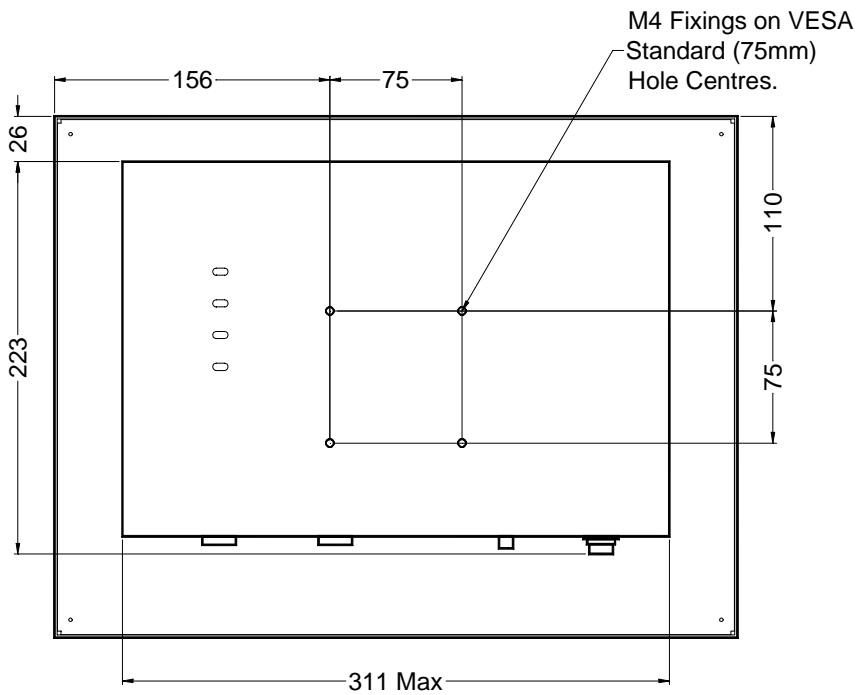

All dimensions in millimetres
(Not to scale)

BOTTOM VIEW

